



Negative skin friction on piles based on partial safety factor

Prof. Dr.-Ing. Hans-Georg Kempfert

Dr.-Ing. Berhane Gebreselassie

Institute of Geotechnics and Geohydraulics, University of Kassel

1 Introduction

The effect of the negative skin friction on pile foundations arises from a relative displacement of the soil and the pile in axial direction. This relative displacement is normally caused by settlement of a compressible soil layer, which in turn may be resulted for example due to additional surface loads, consolidation of the compressible soil layer or groundwater level fluctuations. The weight of the compressible soil layer and the layer above it will hang on the pile shaft due to the skin friction and produces a down-drag force on the pile. This skin friction is opposite to the shaft resistance arising from pile settlement only, therefore, it is designated as negative skin friction. A negative skin friction may also be developed in tension piles in bottom slabs anchorage system due to heave of the soil surrounding the pile.

The negative skin friction can be estimated using the total safety factor concept in different ways (Fedders 1977). The two commonly used procedures are:

- reduction of the pile resistance by an amount equal to the downdrag force (reduced pile bearing capacity), or
- increase of the pile load by amount equal to the downdrag force.

This leads to different total safety factors for the pile foundation.

According to the new partial safety factor principle, however, the negative skin friction on piles is clearly defined as an action, which leads to an additional downdrag force F_n on piles. For the practical verification of safety of the pile foundation, a distinction should be made between the serviceability and ultimate limit states (SLS and ULS respectively), in which each limit state requires different input value of the negative skin friction.

In this paper, the problem regarding verification of safety of pile foundations subjected to the downdrag force according to the new DIN 1054:2005-01 developed based on the partial safety factor concept is presented and the procedure of verification of the SLS and ULS is illustrated by means of an example. Further information can be found for example in (Kempfert 2005).

2 Neutral point and load cases

The actions arising from the negative skin friction together with the actions from the structural loads are in equilibrium with pile base resistance depending on the settlement. Fig. 1 shows an illustration of the interrelationship between these forces for two cases:

- when the action F_a from structural load is relatively low and thus small pile settlement s_a , the part of the actions arising from the negative skin friction F_n becomes larger and the influence of τ_n extends further deep.
- On the other hand, a large actions from structural load F_b may give rise to a higher pile settlement and can lead to the mobilisation of the shaft resistance q_s due to the relative movements between soil and pile.

The point where the negative skin friction changes over to positive shaft resistance is called the neutral point.

In the new DIN 1054:2005-01, the negative skin friction is defined as permanent action, even if its effect possibly ceases after end of the consolidation settlement. The smallest partial safety factor γ_G for permanent actions is allocated to the negative skin friction in the ULS in order to avoid an overestimation of this part of actions.

Independent from the above specification, the norm however leaves room for further interpretation of the negative skin friction in regard to the load cases LF 1

and LF 2. An appropriate interpretation is left to a geotechnical expert. For details on this issue, refer to (Kempfert 2005).

pile and soil settlement

Acting forces on pile

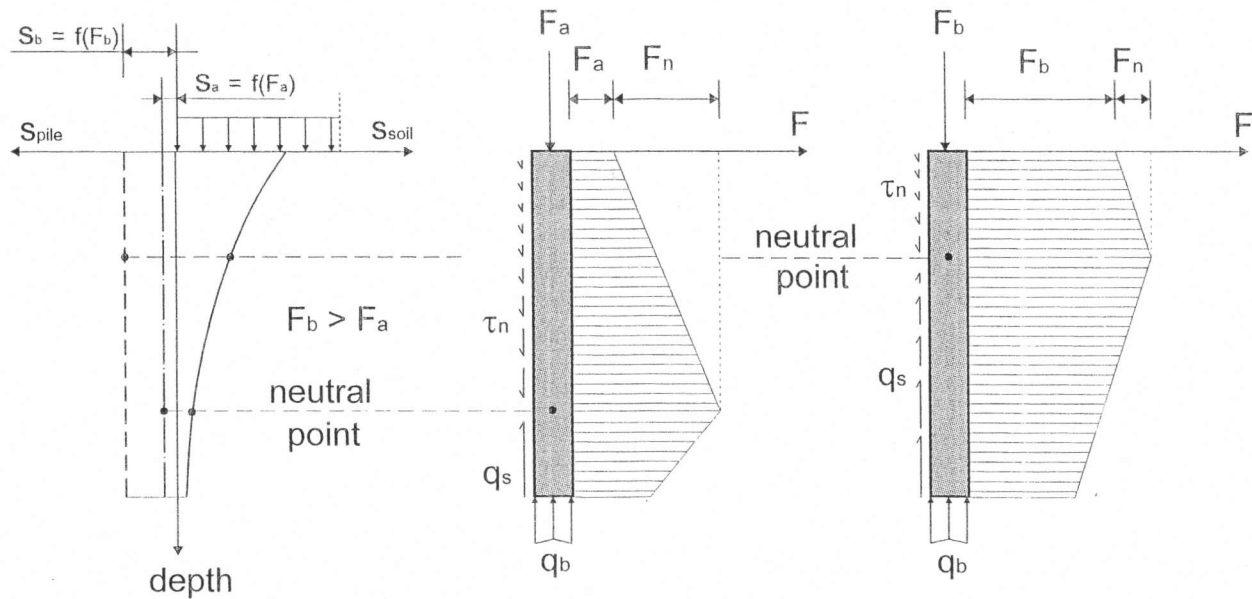

Fig. 1 Qualitative illustration of the interrelationships between the pile resistance, actions from structural load, negative skin friction and the neutral plane of piles in homogeneous soil (Kempfert 2001). Note: only a change in axial pile direction is presented in the diagrams.

3 The characteristic actions arising from negative skin friction

An appropriate estimation of the negative skin friction $\tau_{n,k}$ on a pile requires the following information:

- the distribution of the pile settlement with depth,
- the distribution of the settlement of the compressible soil layer with depth,
- the relative displacement of the pile and the soil, and
- mobilisation functions for $\tau_{n,k}$ and $q_{s,k}$, if necessary

Approximate characteristic values of the negative skin friction $\tau_{n,k}$ can be found in DIN 1054:2005 01 for cohesive and non-cohesive soils.

Essentially, there are two approaches usually used in the literature for the determination of the characteristic value of negative skin friction $\tau_{n,k}$:

- The total stress method for cohesive soils:

$$\tau_{n,k} = \alpha \cdot c_{u,k} \quad (1)$$

where α is a factor which determines the magnitude of the characteristic skin friction $\tau_{n,k}$ for cohesive soils and $c_{u,k}$ is the characteristic undrained strength of cohesive soils.

The value of α depends on the properties of the pile material and the surrounding soils and lies between 0.15 and 1.60, whereas α is set to unity in Eq. (24) of the DIN 1054:2005 - 01 and it is generally recommended for cohesive soils.

- The effective stress method for cohesive and non-cohesive soils:

$$\tau_{n,k} = K_0 \cdot \tan \varphi'_k \cdot \sigma'_v = \beta \cdot \sigma'_v \quad (2)$$

where σ'_v is the effective vertical stress, K_0 is the coefficient of the earth pressure at rest, φ'_k is the characteristic value of the angle of internal friction and β is a factor which determines the magnitude of the characteristic skin friction $\tau_{n,k}$ for cohesive and non-cohesive soils.

Depending on the type of soil, the value of β varies between 0.1 and 1.0. Most often a value of $\beta = 0.25$ to 0.30 is used for non-cohesive soils. More and detail information on the values α and β can be found for example in (Kempfert 2001).

The negative skin friction of a non-cohesive fill material above the compressible layer may lead to a large effect of actions on the pile, therefore, the resulting characteristic effects of actions should not be greater than the overburden weight of this layer. This regulation, however, is only meaningful for closely placed piles in a group.

The influence of the negative skin friction extends up to the neutral point. In reality, however, there exist a transition zone where the negative skin friction changes over to positive shaft resistance and this transition is usually assumed as linear. Fellenius 1972 called the transition zone a neutral plane. Within the transition zone, the negative skin friction is therefore not fully mobilised. The length of the neutral plane depends on the relative displacement between pile and soil (Fig. 2). The smaller the angle α between the intersecting settlement lines of the pile

and soil, the more will be the transition zone from negative to positive skin friction.

For practical applications, the neutral point only is assumed without the transition zone between τ_n and q_s . The maximum effects of action on the pile in axial direction occurs in each case at this point, since the total downdrag force of the downward directed actions arising from the negative skin friction increases and no load reduction can take place up to this point, since no pile resistance is mobilised here. Furthermore, the settlement of the pile coincides with the settlement of the surrounding soil at the neutral point.

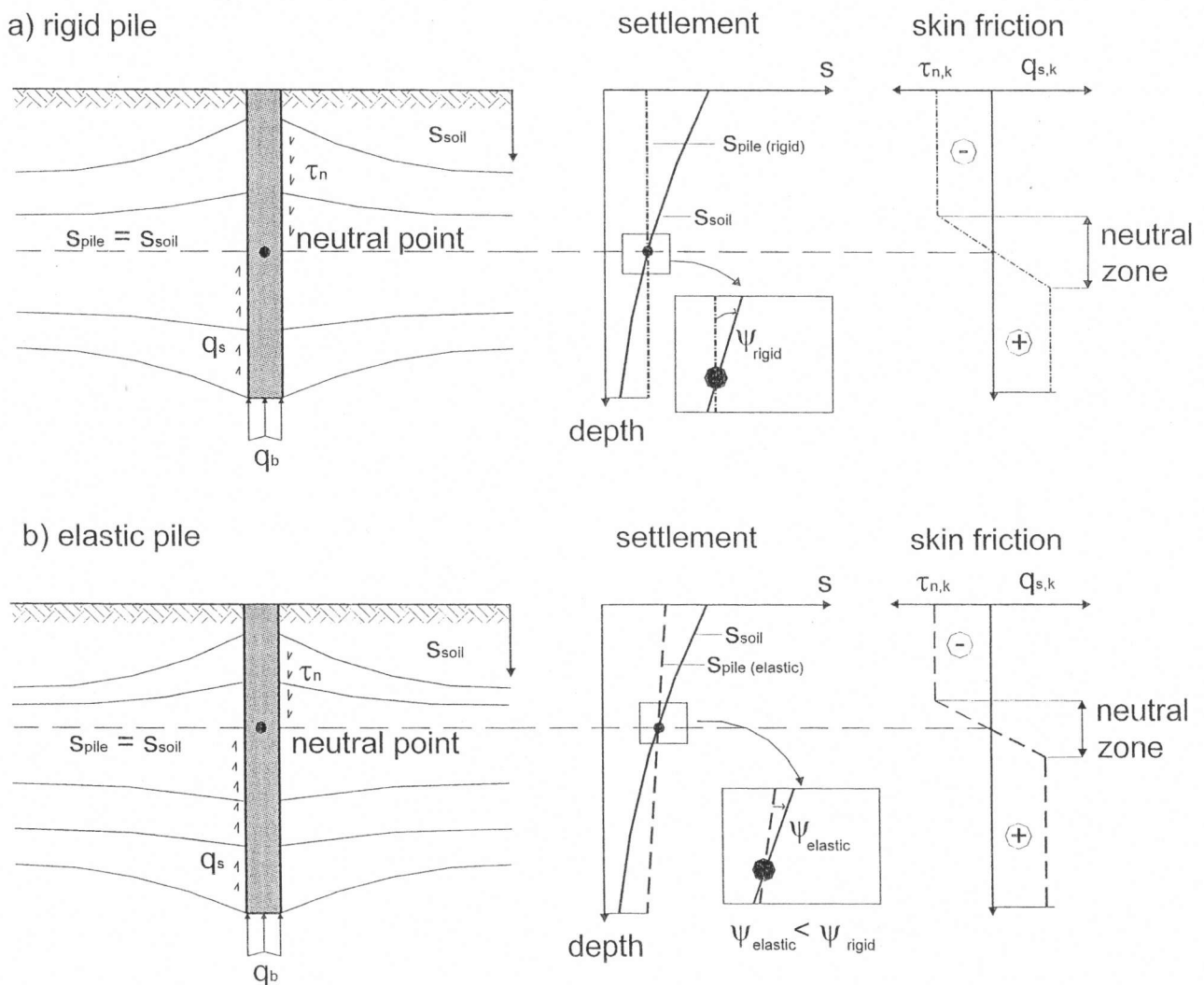

Fig. 2 Overview of the negative skin friction and the mobilisation of the pile shaft resistance depending on the intersection angle of the settlement lines of the pile and soil α ; a) rigid pile, b) elastic pile (originally from Fellenius 1972, adopted from Kempfert 2005).

The neutral point is located near the pile toe in case of end bearing piles, whereas it is usually located in the above half of the pile in case of friction piles.

In the determination of the location of the neutral point in the serviceability limit state (GZ 2) and hence the magnitude of the characteristic action $F_{n2,k}$, it is usually recommended to calculate the settlement of the surrounding soil s_n using the characteristic parameters for the final condition (drained condition), i.e., with due consideration of the consolidation and creep settlement. A comparison of the pile settlement s_2 and the settlement of the soil s_n gives the location of the neutral point.

In the ultimate limit state (GZ 1B), it is recommended to set the pile settlement s_1 according to the selected pile bearing capacity calculation method in ULS (GZ 1) in the determination of the location of the neutral point and the magnitude of the characteristic actions $F_{n1,k}$. A comparison of s_1 and s_n gives the location of the neutral point in the ULS (GZ 1), which can be located differently as that in the SLS (GZ 2).

The estimated pile settlements in the ULS (GZ 1) do not normally occur in reality under the applied working loads (characteristic actions). The verification of the bearing capacity in ULS (GZ 1B) thus takes place on basis of a fictitious deformation state.

4 The design values of actions and effects of actions

It is recommended to assume a load case LF 1 for the actions arising from negative skin friction, if

- the negative skin friction during the entire period of the pile is available, and the deformed compressible soil layer as a permanent action remains attached to the pile even after the settlement of the compressible soil gradually ceases.

The load case LF 2 is determining, if

- the definition in DIN 1054:2005-01 for the negative skin friction as actions applies, i.e., “the combination actions EK 1 (permanent actions) in connection with safety class SK 2 (condition of the structure due to construction measures near the structure)”. For example, a temporary fill near

a pile foundation that result a negative skin friction on the pile can be classified as action.

The design value of actions is given by:

$$F_{nl,d} = F_{nl,k} \cdot \gamma_{Gv} \quad (3)$$

where deviant from DIN 1054:2005 01, $\gamma_G = 1.20$ (against 1.35) for the load case LF 2 is recommended for the verification of the external safety of the pile in the ULS (GZ 1), since actions arising from negative skin friction cannot normally cause a real ultimate limit of the external bearing capacity of piles. For non-ductile pile foundation systems, e.g. piles on rocks, the load case LF 1 is determining.

For the verification of the pile against material failure, the partial safety factor γ_G is always used for the load case LF 1 similar to other foundation types.

5 Illustrative example

5.1 The problem

A verification of the safety in the ULS and SLS is required for a precast reinforced concrete displacement pile square in form with side length $a_s = 0.35$ m and subjected to a permanent action $F_{G,k} = 0.450$ MN (Fig. 3a). The results of a static pile load test is given in Fig. 3b.

Soil layer	Soil parameter
Fill material (Sand)	$\varphi'_k = 30^\circ, \gamma = 16.0 \text{ kN/m}^3$
Compressible soil	$c_{u,k} = 35.0 \text{ kN/m}^2$

Table 1 Characteristic values of soil parameters

A settlement of 5 cm is calculated for the compressible soil layer under a uniform surface load due to infinite fill, whereas the settlement of the bearing layer is

neglected. A permissible pile head settlement of 0.5 cm is assumed in the SLS (GZ 2). Furthermore, the pile is assumed rigid.

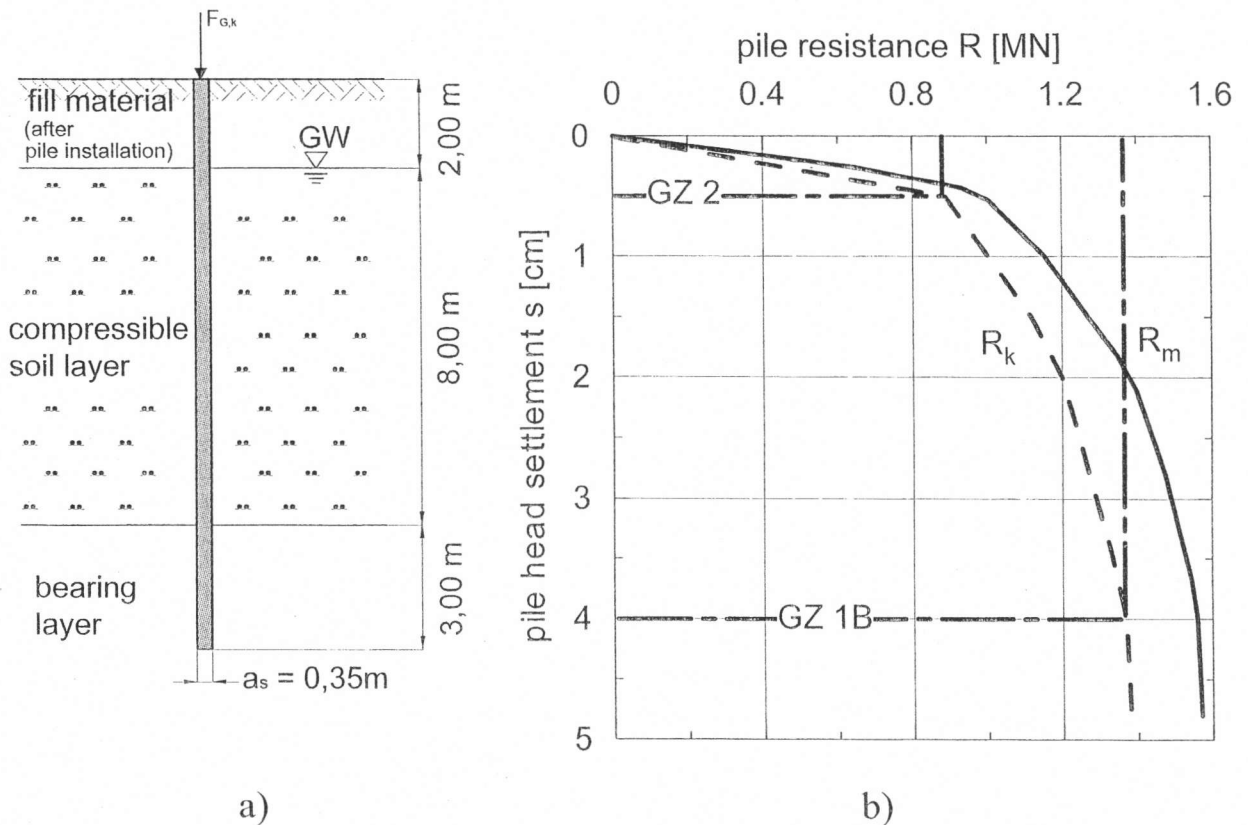

Fig. 3 a) The pile system and the boundary condition; b) result of a pile load test and cone penetration test as well as the derived pile resistance-settlement lines.

5.2 Determination of the characteristic resistance-settlement lines

The characteristic resistance-settlement lines can be determined using Eq. (26) of DIN 1054:2005 01 and are given in Table 2 (see also Fig. 3b). A pile head settlement $s_1 = 0.10 \cdot D_b$ is set for ULS (GZ 1B), provided that no other criteria is selected. For square piles, an equivalent pile diameter $D_{Ers} = 39.5$ cm is calculated. Hence,

$$s_1 = 0.10 \cdot 39.5 = 3.95 \text{ cm} \approx 4 \text{ cm}$$

Therefore, the characteristic pile resistance in ULS according to Table 2 is:

$$R_{1,k} = 1380.0 \text{ kN}$$

In the SLS, the characteristic pile resistance according to Fig. 3b and Table 2 is:

$$R_{2,k} = 850.0 \text{ kN}$$

s [cm]	R_m [MN]	ξ [-]	$R_{1,k} = R_m/\xi$ [MN]
0.0	0.000	1.15	0.000
0.5	0.978	1.15	0.850
1.0	1.198	1.15	1.042
1.5	1.320	1.15	1.148
2.0	1.410	1.15	1.226
3.0	1.532	1.15	1.332
4.0	1.587	1.15	1.380
4.7	1.587	1.15	1.380

Table 2 Pile load test results and derivation of the characteristic pile resistance-settlement lines

N.B.: It is approximately assumed that the pile resistance from the pile load test arises purely from the load bearing layer and no contribution from the other layers.

5.3 The characteristic actions $F_{n,k}$ arising from negative skin friction

Fig. 4 shows a plot of the pile settlement under actions $F_{G,k}$ in the ULS (GZ 1B) and SLS (GZ 2) against the settlement of the compressible soil layer.

In the ULS (GZ 1B), the neutral point is located in the compressible soil layer 2.3 m under the surface (Fig. 4). Using Eq. (1) for the soft layer and Eq. (2) for the fill layer, the characteristic actions arising from negative skin friction are calculated as shown in Table 3.

Depth [m]	d_i [m]	$A_{s,i}$ [m ²]	$\tau_{n,k,i}$ [kN/m ²]	$F_{n,k,i}$ [kN]
0.00	2.00	2.80	0.0	12.9
2.00			9.2	
2.00	0.30	0.42	35.0	14.7
2.30				

$F_{n1,k} = 27.6 \text{ kN}$

Table 3 Actions arising from negative skin friction in ULS (GZ 1B)

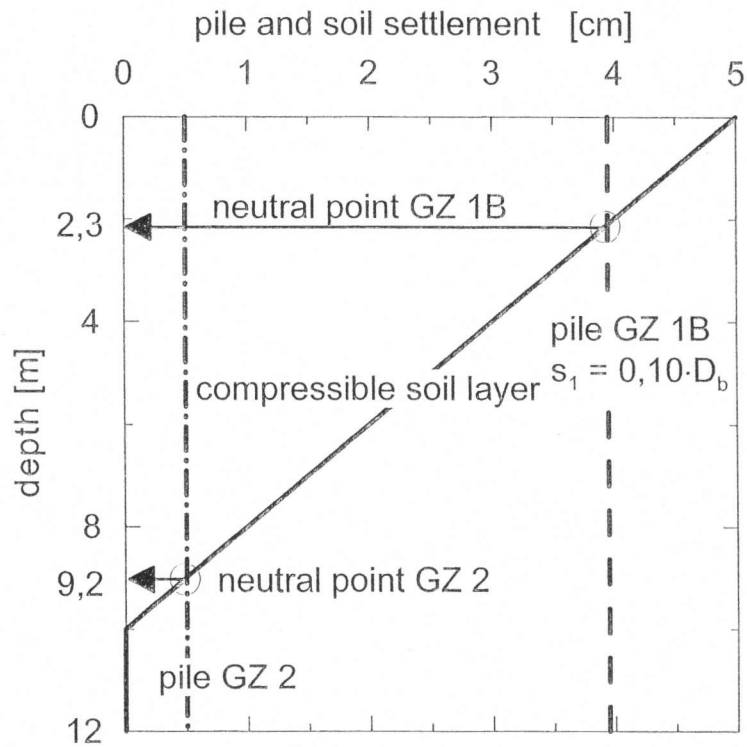

Fig. 4 Determination of the neutral points from the pile and soil settlements in the limit states (GZ 1B and GZ 2)

In the SLS (GZ 2), the neutral point is located in the compressible soil layer 9.2 m under the surface. The characteristic actions arising from negative skin friction are calculated and summarised in Table 4.

Depth [m]	d_i [m]	$A_{s,i}$ [m ²]	$\tau_{n,k,i}$ [kN/m ²]	$F_{n,k,i}$ [kN]
0.00	2.00	2.80	0.0	12.9
2.00			9.2	
2.00	7.20	10.08	35.0	352.8
9.20				
				$F_{n2,k} = 365.7 \text{ kN}$

Table 4 Actions arising from negative skin friction in SLS (GZ 2)

5.4 Verification of the bearing capacity in ULS

For the verification of the bearing capacity of piles in ULS (GZ 1B), the following equation must be satisfied:

$$E_{1,d} \leq R_{1,d}$$

The negative skin friction is assumed as a permanent action in load case LF 2. Thus,

$$E_{1,d} = (F_{G,k} + F_{n1,k}) \cdot \gamma_G = 450.0 \cdot 1.35 + 27.6 \cdot 1.20 = 640.6 \text{ kN}$$

$$R_{1,d} = R_{1,d} / \gamma_{Pc} = 1380.0 / 1.20 = 1150.0 \text{ kN}$$

$$E_{1,d} = 640.6 \text{ kN} \leq R_{a,d} = 1150.0 \text{ kN}$$

5.5 Verification of the serviceability

In the serviceability limit state, the following condition must be fulfilled:

$$E_{2,d} \leq R_{2,d}$$

where

$$E_{2,d} = E_{2,k} = F_{G,k} + F_{n2,k} = 450.0 + 365.7 = 815.7 \text{ kN}$$

$$R_{2,d} = R_{2,k} = 850.0 \text{ kN}$$

$$E_{2,d} = 815.7 \text{ kN} \leq R_{2,d} = 850.0 \text{ kN}$$

References

Fedders, H. (1977)

Stand der Normung, Bemessung und Ausführung von Rammpfählen. Vortragsband Pfahlsymposium München (DGEG), 33-43

Fellenius, B. H. (1972)

Down-Drag on piles in clay due to negative skin friction. Canadian Geotechnical Journal, 323-337

Kempfert, H.-G. (2005)

Kommentar zum Abschnitt Pfahlgründungen. Kommentar zur DIN 1054:2005-01 (in Vorbereitung)

Kempfert, H.-G. (2001)

Pfahlgründungen (Abschnitt 1-7). Grundbautaschenbuch, 6. Auflage, Teil 3, Kapitel 3.2, Ernst & Sohn, 87-206